

Ultimate-Precision Digital LBB



- High precision digital gaging system
- Drop-in replacement for Solartron Orbit®2
- Fits on the Orbit®2 T-Connector in existing installations (no need to replace it)
- Spring or air actuated digital gages
- Robust cast aluminum case (electronics)
- Stackable with T-Connectors for networking
- T-Connector available separately
- USB interface available (with COM libraries)
- Up to 31 devices on USB with external power
- External power supply available

DESCRIPTION

The Ultimate-Precision Digital LBB gaging system consists of digital gaging probes daisy chained in a network using T-Connectors (available separately) with DE-9P and -9S connectors. Each Digital LBB gaging probe includes a highly repeatable analog AC LVDT (Linear Variable Differential Transformer) gaging probe guided with a precision linear ball bearing, mated to an in-line digital I/O signal conditioning module. The circuitry and firmware feature digital calibration and linearity correction of the digital output position signal with very high accuracy.

The Ultimate-Precision Digital LBB gaging probes are drop-in replacements for Solartron's devices for the Orbit®2 system and therefore do not require replacement of the Solartron T-Connector in existing applications. They operate in conjunction with the Solartron PCI card or USB module, as well as with our available USB interface (male connector to be connected to one of these interfaces). Our robust dimensional gaging probes are engineered to provide highly precise and repeatable measurements in various industrial, quality assurance and metrology applications.

The system is based on an RS-485 half duplex, multi-drop network providing plug-and-play compatibility with the Orbit® bus measurement system. The Digital LBB gaging probes convert their position signal into digital data which is then transmitted by the RS-485 network using asynchronous transmission (poll/response). The devices support both standard and buffered modes. Our LBB USB 2.0 full speed compliant interface device (available separately) can be connected to this network (using a T-Connector) to communicate with and allow data transfer to a computer. When our USB interface is plugged into a computer running a Windows® operating system, the Device Manager (in the section "Universal Serial Bus Controllers") of the Computer Management console displays the name "Meas-Spec Digital LBB Serial Converter", clearly identifying our Digital LBB device amongst others.

The available LBB external power supply is capable of supplying (2 Amps) 31 Digital LBB gaging probes. It features an integral T-Connector which is permanently attached to it. This special T-Connector will interrupt the bus power (power-in pins removed from the male connector) and switch it over to the external power supply, for all Digital LBB gaging probes connected downstream (female connector side). However, if any Digital LBB gaging probes are connected upstream (male connector side) the external power supply, then they will be bus powered.

The data sheet for our Ultra-Precision LBB (Linear Ball Bearing) AC gage probes can be found at:
http://www.meas-spec.com/downloads/LBB_Series.pdf

Measurement Specialties, Inc. (NASDAQ MEAS) offers a full range of genuine Schaevitz® position sensors, signal conditioners, as well as many other types of sensors. Data sheets can be downloaded from our web site at: <http://www.meas-spec.com/datasheets.aspx>

Ultimate-Precision Digital LBB

FEATURES

- Drop-in replacement for Solartron Orbit®2
- Mounts into existing Orbit®2 applications without the need for T-Connector replacement
- High resolution 14-bit digitizing module
- Built-in digital linearity correction
- Robust probes with precision linear ball bearing
- Very easy to setup and use (Plug-and-play)
- USB bus or externally powered (both available)
- USB device name for easy Windows® recognition
- RoHS and CE Mark (Excellent noise immunity in industrial environments), all devices

APPLICATIONS

- Factory automated inspection systems (i.e. engine pistons, bearings, etc.)
- Free-form measurements (i.e. airfoils, windshields, crankshafts, camshafts)
- Wobble/runout of rotating parts (i.e. brake rotors, axles)
- Optics Inspection Systems (i.e. mirrors, lenses)
- Materials testing
- SPC data collection
- Metrology
- Actuation controls
- Other precision dimensional measurements

SPECIFICATIONS

Parameter	Specification	Comment
Measurement ranges	1, 2, 5, and 10 mm	
Linearity	±0.05% of range	
Accuracy	0.1% of reading	Ranges up to 2mm
	0.2% of reading	Ranges over 2mm
Repeatability	0.006% of range	
Calibration temperature	22 ± 4°C	
Resolution	14 bits	
Operating voltage	5.00 ± 0.25 Volts DC	
Operating current	<60mA	
Operating temperature	0 to +60°C	
Storage temperature	-20 to +70°C	Dry air environment
Maximum operating relative humidity	60%	Non-condensing
Standard and Buffered mode sampling rate	240 readings per second	
Buffer size	3000 Samples	
Dynamic mode sampling rate	Not supported at this time.	In development
Bus format	8 Bits, 1 Stop, Odd Parity	
Bus baud rate	187.5Kbd	Standard & buffered modes
Bus protocol	Proprietary device addressable	
Bus interface	RS-485	
Max number of Digital LBB gaging probes on USB	4 (on USB bus power)	Plus USB interface (<300mA)
	31 (on external power)	
External power supply output current	2 Amps	Available separately
Cable length	2 meters	
Cable materials	Copper lead-wires with FEP insulation, copper shield, and overall polyurethane jacket	
Weight (device without T-Connector)	115 grams	
Weight of T-Connector	50 grams	Available separately
Weight of USB interface	115 grams	Available separately
Housing material, electronics	Aluminum, epoxy powder coated	

Orbit® is a registered trademark of Solartron Metrology

Windows® is a registered trademark of Microsoft Corporation

Ultimate-Precision™ Digital LBB

DRAWINGS AND DIMENSIONS

Digital LBB gaging probe

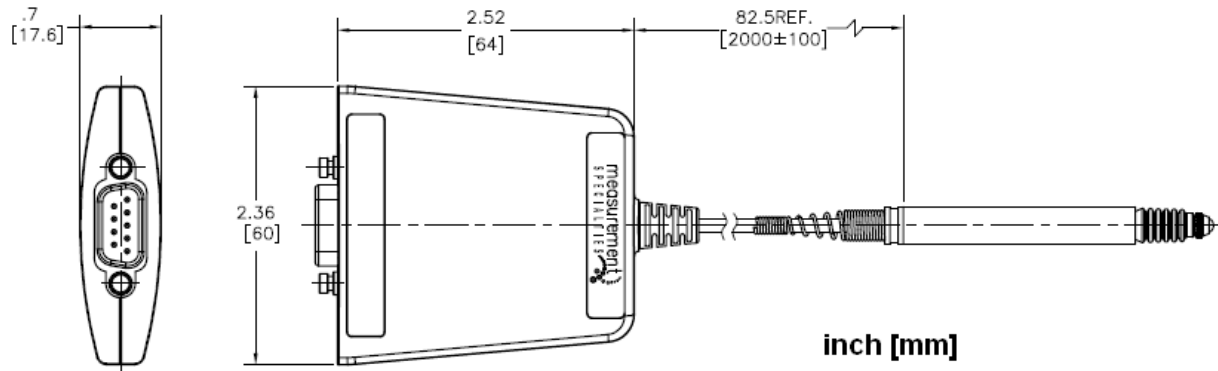

T-Connector

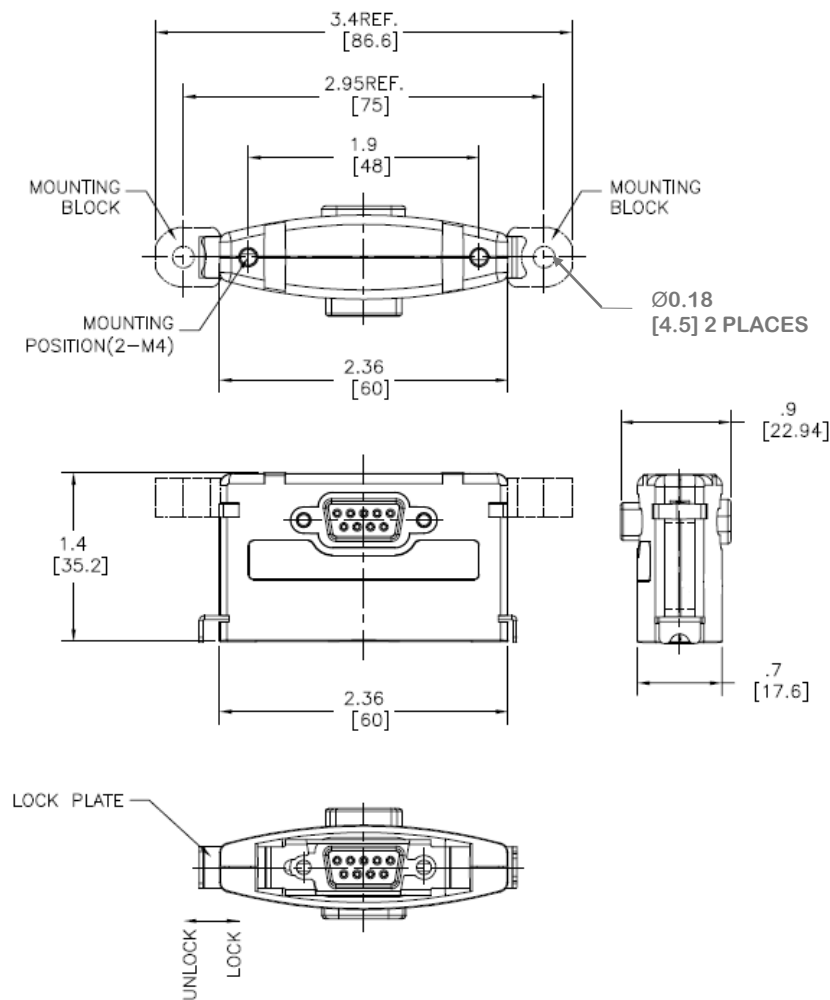

Ultimate-Precision™ Digital LBB

Power Supply Kit (3 components)

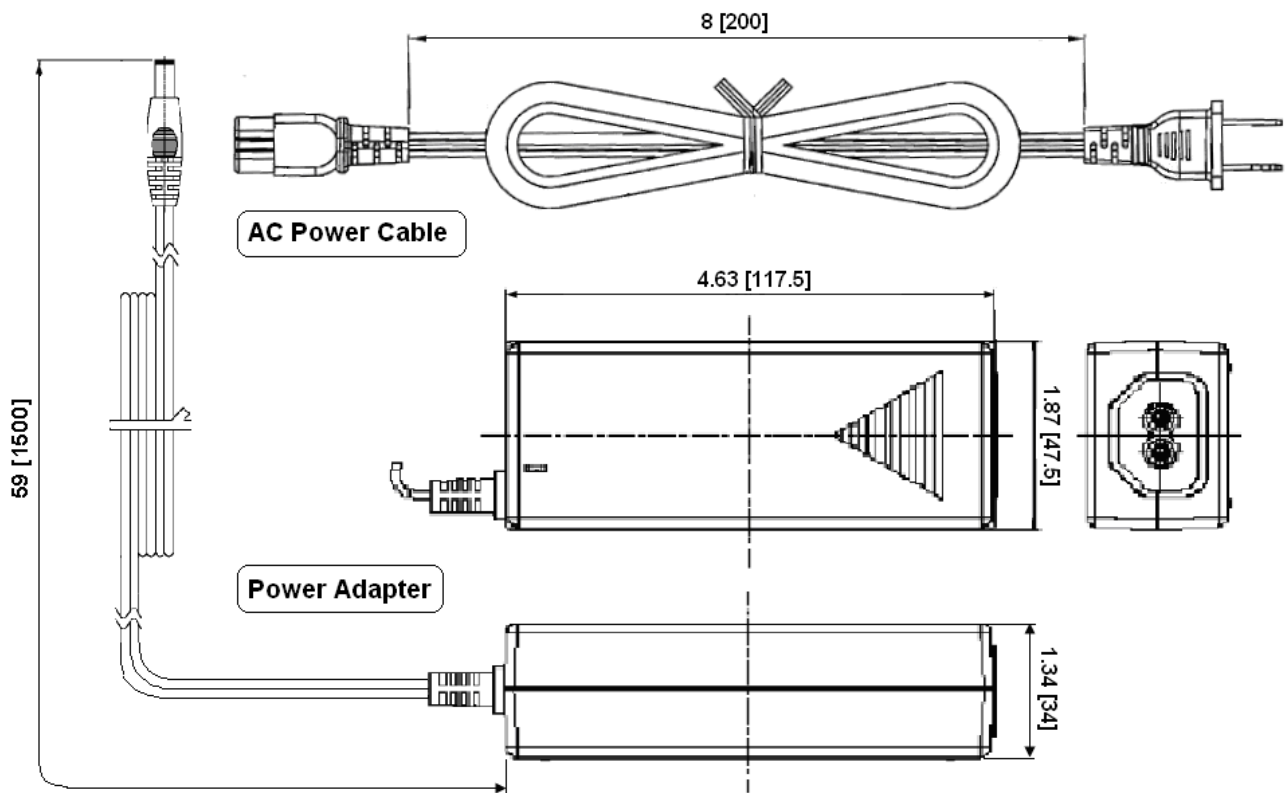
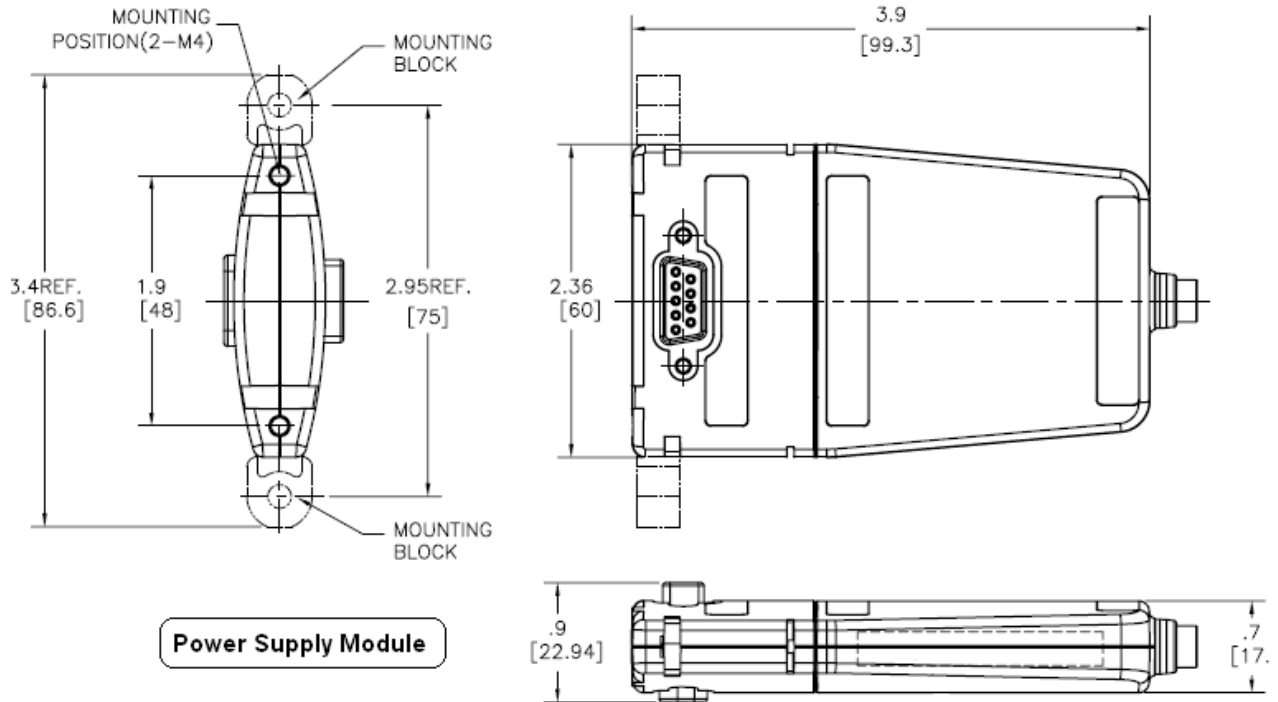

Ultimate-Precision™ Digital LBB

USB Interface

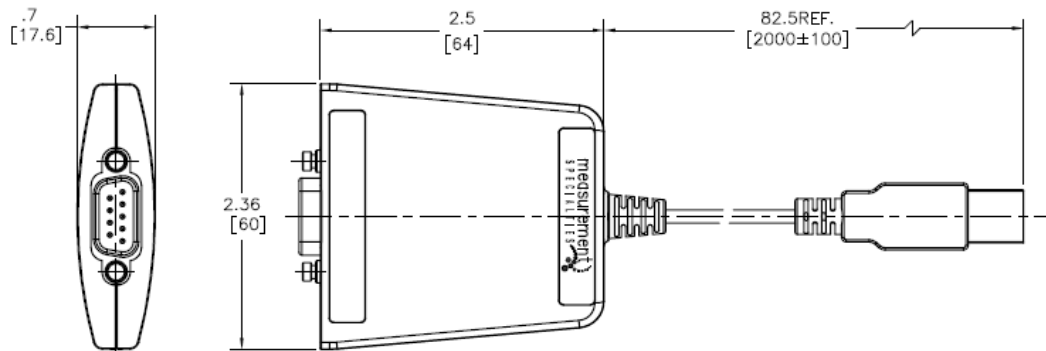

ORDERING INFORMATION

Description	Model	Part No (Status)
USB interface device for DLBB	LBB DIGITAL USB INTERFACE	72290002-000 (√)
T-Connector for DLBB	LBB DIGITAL BACKPLAIN	72290003-000 (√)
Power supply kit for DLBB (100-240VAC, 50/60Hz input; 5VDC, 2A out)	LBB DIGITAL USB POWER SUPPLY	72290004-000 (√)
8mm diameter digital gaging probe, 2mm range, spring push	DLBB315PA-040	72350012-000 (√)
3/8" diameter digital gaging probe, 2mm range, spring push	DLBB375PA-040	72350013-000 (√)
3/8" diameter threaded digital gaging probe, 2mm range, spring push	DLBB375TA-040	72350014-000 (√)
8mm diameter digital gaging probe, 5mm range, spring push	DLBB315PA-100	72350015-000 (√)
3/8" diameter digital gaging probe, 5mm range, spring push	DLBB375PA-100	72350016-000 (√)
3/8" diameter threaded digital gaging probe, 5mm range, spring push	DLBB375TA-100	72350017-000 (√)
8mm diameter digital gaging probe, 2mm range, pneumatic push	DLBB315PA-040A	72350024-000 (*)
3/8" diameter digital gaging probe, 2mm range, pneumatic push	DLBB375PA-040A	72350025-000 (*)
3/8" dia. threaded digital gaging probe, 2mm range, pneumatic push	DLBB375TA-040A	72350026-000 (*)
8mm diameter digital gaging probe, 5mm range, pneumatic push	DLBB315PA-100A	72350021-000 (*)
3/8" diameter digital gaging probe, 5mm range, pneumatic push	DLBB375PA-100A	72350022-000 (*)
3/8" dia. threaded digital gaging probe, 5mm range, pneumatic push	DLBB375TA-100A	72350023-000 (*)
8mm diameter digital gaging probe, 1mm range, spring push	DLBB315PA-020	72350009-000 (-)
3/8" diameter digital gaging probe, 1mm range, spring push	DLBB375PA-020	72350010-000 (-)
3/8" diameter threaded digital gaging probe, 1mm range, spring push	DLBB375TA-020	72350011-000 (-)
8mm diameter digital gaging probe, 10mm range, spring push	DLBB315PA-200	72350018-000 (-)
3/8" diameter digital gaging probe, 10mm range, spring push	DLBB375PA-200	72350019-000 (-)
3/8" diameter threaded digital gaging probe, 10mm range, spring push	DLBB315PA-200A	72350020-000 (-)

(√) Available for immediate ordering

(*) Summer 2011 availability

(-) In Development

Ultimate-Precision™ Digital LBB

ORDERING INFORMATION

NORTH AMERICA	EUROPE	ASIA
Measurement Specialties, Inc. 1000 Lucas Way Hampton, VA 23666 United States Phone: +1-800-745-8008 Fax: +1-757-766-4297 Email: sales@meas-spec.com Web: www.meas-spec.com	MEAS Deutschland GmbH Hauert 13 D-44227 Dortmund Germany Phone: +49-(0)231-9740-0 Fax: +49-(0)231-9740-20 Email: info.de@meas-spec.com Web: www.meas-spec.com	Measurement Specialties China Ltd. No. 26, Langshan Road High-tech Park (North) Nanshan District, Shenzhen 518057 China Phone: +86-755-33305088 Fax: +86-755-33305099 Email: info.cn@meas-spec.com Web: www.meas-spec.com

The information in this sheet has been carefully reviewed and is believed to be accurate; however, no responsibility is assumed for inaccuracies. Furthermore, this information does not convey to the purchaser of such devices any license under the patent rights to the manufacturer. Measurement Specialties, Inc. reserves the right to make changes without further notice to any product herein. Measurement Specialties, Inc. makes no warranty, representation or guarantee regarding the suitability of its product for any particular purpose, nor does Measurement Specialties, Inc. assume any liability arising out of the application or use of any product or circuit and specifically disclaims any and all liability, including without limitation consequential or incidental damages. Typical parameters can and do vary in different applications. All operating parameters must be validated for each customer application by customer's technical experts. Measurement Specialties, Inc. does not convey any license under its patent rights nor the rights of others.